

***Sinexcel***



## **SEC Series DC Fast Charger**

# **Maintenance manual**

Issue 01  
Date 2020-10-30

© Copyright 2020 Sinexcel. All rights reserved

## Disclaimer

We do not assume the responsibility of free maintenance for personal electric shock, product damage, failure or defects for the following reasons:

- Non-professional operation and maintenance personnel or operators who do not have the relevant operating license maintain the product without authorization, resulting in damage of the product;
- The product is not maintained regularly and properly according to the requirements of the maintenance manual, resulting in damage or failure of the product;
- The product is not maintained in accordance with local specifications and standards;
- Maintenance activities not filed or not reported to the equipment supplier cause product damage and failure;
- In the process of maintenance, the original design of the product is changed without authorization, resulting in damage or failure of the product.
- Product damage or failure is caused intentionally or by mistake in the process of maintenance;
- Product damage or failure is due to force majeure (such as a bad weather, natural disasters, etc.) in the process of maintenance;
- The maintenance personnel do not wear protective equipments before entering the field, resulting in personal electric shock and equipment damage;
- The front-end power supply of the equipment has not been stopped before maintenance, resulting in personal electric shock and equipment damage;
- In the maintenance, the type of failure of equipment or reasons of failure is not identified, or the circuit is changed without consulting the supplier resulting in equipment damage;
- After maintenance, the door lock is not closed as required, resulting in damage to the insulation of the equipment caused by water or other foreign matters in the equipment.
- After maintenance, the device with a failure is not marked clearly and sent back to the supplier for analysis;
- After maintenance, the device with a failure is discarded carelessly, resulting in the absence of cause of failure.

## Solemn declaration:

Before maintenance, please ensure that the front-end power supply has been reliably switched off; and before another power-on test, please ensure that the failure has been eliminated and the electric circuit has been connected properly.

Personnel who maintain the equipment, including operators, trained personnel and professionals, shall be qualified for special operations such as high-pressure operations, working at heights and operations of special equipments as prescribed by the state.

**All rights reserved: All the copyrights belong to our company. We reserve all the rights.**

## Preface



### Readers

This document (This guide) is mainly applicable to the following engineers:

- Technical Support Engineer
- Maintenance Engineer

### Symbols

The following symbols may appear in this document, and they have the following meanings.

Symbol	Meaning
	<b><i>Danger</i></b> Hazardous voltage Hazardous voltage can cause death or injuries
	<b><i>Warning</i></b> Risk warning It may cause equipment damages and personal injuries
	<b><i>Caution</i></b> Harms Failure to comply may result in equipment damages or functional failure.









---

# Contents

<b>1</b>	<b>Safety instructions</b> .....	<b>1</b>
1.1	Warning and danger .....	1
1.2	Maintenance instructions .....	1
<b>2</b>	<b>Maintenance</b> .....	<b>3</b>
2.1	Maintenance when the charger is not used for a long time .....	3
2.2	Charger maintenance items and checking cycle .....	3
<b>3</b>	<b>Replacement of common devices</b> .....	<b>5</b>
<b>4</b>	<b>Guidance for replacement of dust screen</b> .....	<b>11</b>
<b>5</b>	<b>Common troubleshooting</b> .....	<b>14</b>
<b>6</b>	<b>Emergency unlock</b> .....	<b>15</b>

# 1 Safety instructions

## 1.1 Warning and danger

Symbol	Meaning of symbol	Description
	<i>Danger</i>	Because some parts of the power system are at a high pressure during operation, the direct or indirect contacting with these components, such as contacting through wet things, can be fatal.
	<i>Danger</i>	The high-voltage line construction operation may cause fire or electric shock. The connecting area and the passing area of the AC cable must comply with the national regulations and specifications. Only those who have the ability to work at a high DC and high AC voltage can install and maintain the DC charger.
	<i>Danger</i>	It is strictly forbidden to do the on-site maintenance work in a bad weather.
	<i>Danger</i>	It is strictly forbidden to maintain when the equipment is live.
	<i>Warning</i>	Special tools must be used in all kinds of operations at high DC and AC voltages.
	<i>Warning</i>	When handling the equipment by hands, wear protective gloves to prevent injuries caused by sharp objects.
	<i>Caution</i>	Please read the maintenance manual carefully before maintenance.
	<i>Caution</i>	Before maintenance, please wear personal protective tools to avoid injuries in the process. After maintenance, do not leave tools in the equipment to avoid the short circuit.
	<i>Caution</i>	The maintenance shall follow the local rules and regulations and meet the requirements of the station.

## 1.2 Maintenance instructions

- This product is high-power and high-voltage power equipment. Construction and maintenance personnel shall work with the operation certificate.
- In the maintenance of the equipment, the relevant construction standards and safety regulations in different places and states shall be strictly followed.
- The equipment is developed, manufactured, checked, filed and certified in accordance with the relevant safety standards. Therefore, the product will not cause property damage or endanger human health under normal circumstances if the instructions for the specified use and technical instructions for safety are followed.

- The instructions contained in this manual must be strictly observed. Otherwise, there may be a safety hazard or failure of the safety device. Although this manual explains the relevant safety instructions, note that safety specifications and accident prevention specifications for the corresponding usage must be complied with.
- In case of any problems and failures in the process of use, the user shall directly consult the supplier. In the warranty period, if he/she asks a third party or non-professional to maintain without authorization any safety consequences shall be borne by the user.
- Please strictly comply with the specifications formulated in this manual or by the station for regular and correct maintenance of the charger.
- Each maintenance shall be recorded, components with a failure shall be identified and , the failure description shall be prepared, and they shall be sent back to the manufacturer for analysis. Do not discard carelessly.
- Do not change the original design of the product without authorization during maintenance.
- Maintenance personnel shall properly wear protective equipment before entering the field to avoid personal electric shock and equipment damage.
- After maintenance, close and lock the door properly so that the insulation of the equipment will not be damaged due to water ingress or other foreign matters.
- There is no lamp inside the charger. The installation and maintenance personnel must bring their own lighting equipments.
- Charger is high-power and high-current equipment with a fatal dangerous voltage. Do not repair and maintain it when it is live.
- Even when all the switches of the charger have been disconnected, the copper bar of the charging line still has a dangerous voltage. During the maintenance of the equipment, it is necessary to turn off the upper switch of the charger, hang the repair sign, and check whether there is a dangerous voltage with an instrument to ensure that the charger is completely disconnected from the power grid.
- It is strictly forbidden to do the maintenance work in a bad weather such as thunderstorms.
- It is strictly forbidden to do the power-on test before troubleshooting.
- Maintenance personnel shall wear professional protective tools, such as protective clothing, insulation boots and insulation gloves, to avoid injuries in the process of maintenance.

## 2 Maintenance

### 2.1 Maintenance when the charger is not used for a long time

When the charger is not used, the charger shall be in a power-off state and the unnecessary load of the charger shall be reduced, so as to increase the service life of the charger.

### 2.2 Charger maintenance items and checking cycle

Checking item	Checking cycle	Checking content	Treatment method
Front-end distribution box	Three months	Each item is checked in accordance with the maintenance manual of the distribution box. (Note: The maintenance manual of the distribution box is provided by the supplier of distribution box.)	Maintenance and repairing
Appearance of equipment	One year	Check the appearance of the cabinet for any stains; Check whether the cabinet shell is flat or has any rust, scratch, deformation, paint damage and other defects.	Cleaning and paint repair
Interior of charger	Every year	Check whether the interior of the cabinet is clean and tidy, and whether the air inlet and outlet of the power module are filled with dust. The dust shall be timely removed to prevent the failure of the power module.	Cleaning
Lightning protector	Every year	Check whether the module is loose and the status indicator is normal. If the status indicator changes to red, the dry contact NC-COM of alarm becomes open or the NC-COM becomes short-circuited, the surge protector has failed.	Replacement
Fan	Half a year	Whether the fan is working properly.	Maintenance and repairing
Signal lamp	Half a year	Check whether the signal lamp is burned out, whether it is fixed tightly or not, and whether it is in a normal state.	Maintenance and repairing
Components	Half a year	Check whether components of the electric circuit have discoloration, deformation and other phenomena, whether the fixation is loose, and whether the connection of the components is burned out. If any abnormality is found, parts shall be replaced in a timely manner.	Maintenance and repairing
Charging connector	Half a year	Check whether the fixing clasp of the charging connector is damaged, whether the needle of the charging connector is oxidized and discolored or obviously worn and deformed, whether any foreign body has entered the hole on the head of the connector, and whether the charging connector cable is damaged.	Cleaning and repairing
Power module	Half a year	Check that the power module is normal and there is a trouble-free display on the module screen.	Maintenance and repairing
Human machine interface	Half a year	Check whether the screen of the display screen is cracked, whether the display is normal, check whether it can operate normally.	Maintenance and repairing

Emergency stop function	Half a year	Press the emergency stop button to check whether the emergency stop button is working normally, and reset the emergency stop button after normal check.	Maintenance and repairing
Equipment grounding	Half a year	Check whether the ground wire of the equipment housing is loose or detached.	Maintenance and repairing
System grounding	Half a year	Check whether the grounding cable inside the cabinet is loose and fall off, whether the grounding sign is complete and obvious, and whether there is any loss and damage.	Maintenance and repairing
Slot	Every year	Check whether the slot is fixed firmly, whether the cover plate is complete and tight.	Maintenance and repairing
Breaker	Monthly	Press the TEST button of the circuit breaker to see whether the circuit breaker can trip properly.	Maintenance and repairing
Electric cable	Every year	Check whether the cable and switch are connected closely, whether the grounding is reliable, whether the power cable is blackened, deformed or damaged, and whether the sealing measures at the incoming cable of the cabinet are intact.	Repairing and replacement of cables
Force majeure factor	Immediately	In case of flood, earthquake, impact, switch trip and other events, the whole machine shall be checked immediately.	Maintenance and repairing



### 3 Replacement of common devices

NOTE: To change devices, do not operate when the charger is live!

#### 1. Electric meter

Tools required: screwdriver

- Replacement steps:
- ① Screw off the screw on the protective cover at the lower end of the electric meter, unscrew the protective cover, and remove the connecting cable of the electric meter;
  - ② Remove the fixing screws at both ends of the connection area of the electric meter and the hanging screws at the upper end of the electric meter. And then the electric meter can be removed;
  - ③ Replace with a new electric meter in the opposite way to disassemble it.

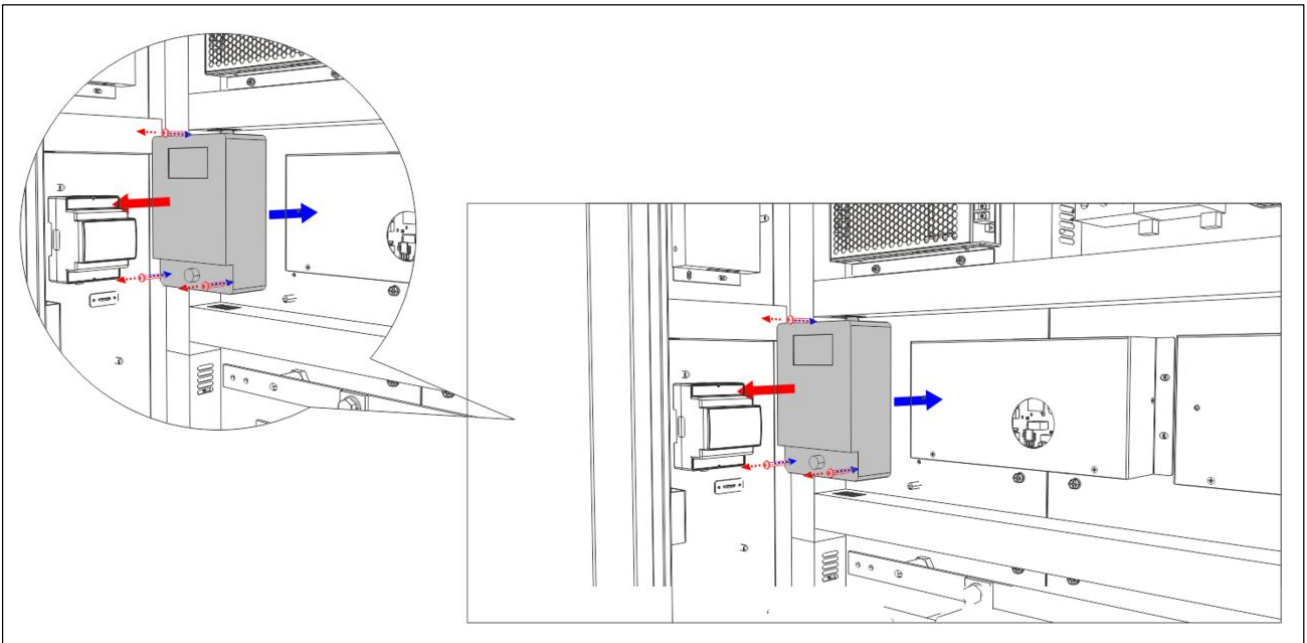

## 2. Main circuit breaker

Tools required: Allen wrench, screwdriver and socket wrench

- Replacement steps:
- ① Remove the screws in the fixed bus bar of the circuit breaker by using an allen wrench;
  - ② Remove the input and output bus bar with a socket wrench;
  - ③ Use a screwdriver to remove the fixing screw at the upper, middle and lower ends of the main circuit breaker. And then the main circuit breaker can be removed.
  - ④ Replace with the new main circuit breaker in the opposite way to disassemble it.

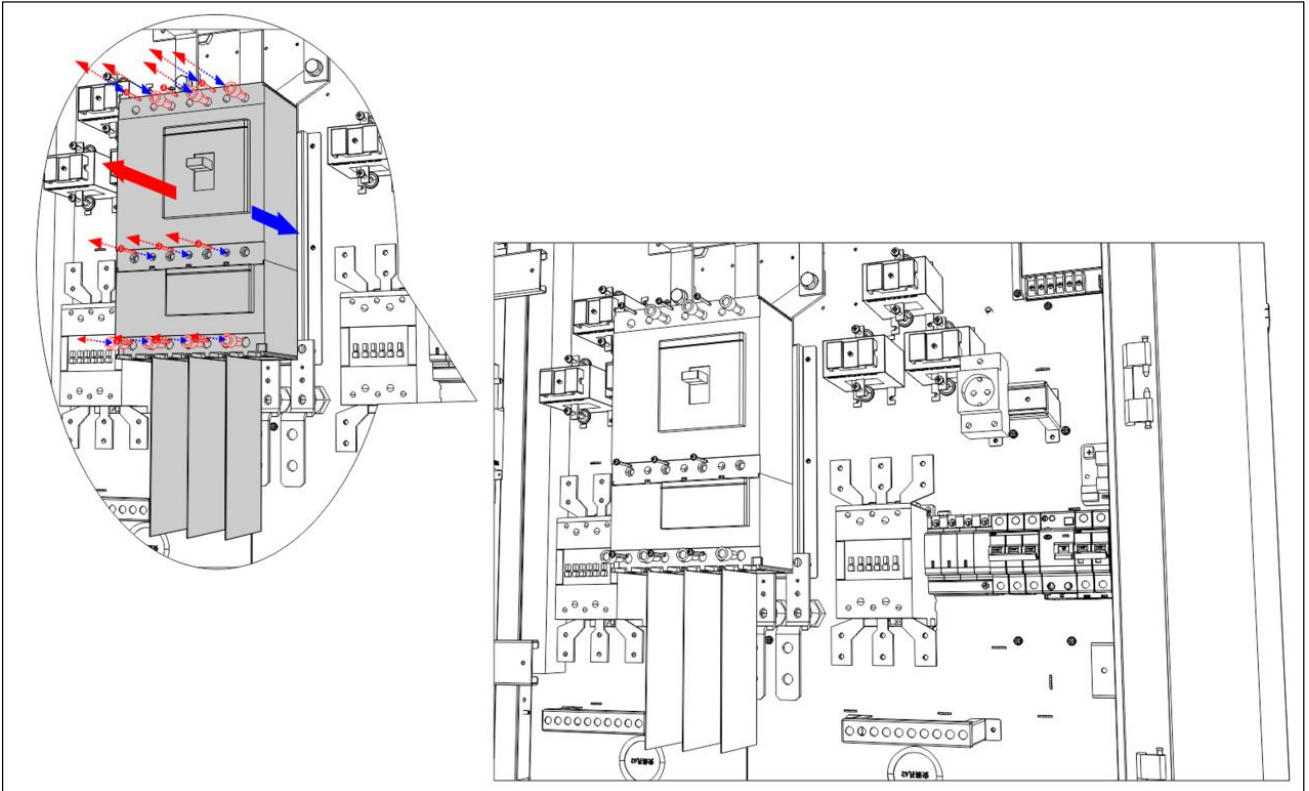

### 3. Cooling fan

Tools required: screwdriver

- Replacement steps:
- ① Separate the terminals of plug-in connectors of the cables of the cooling fan;
  - ② Use a screwdriver to remove the four fixing screws of the fan. And then the fan can be removed;
  - ③ Replace with a new cooling fan in the opposite way to disassemble it.

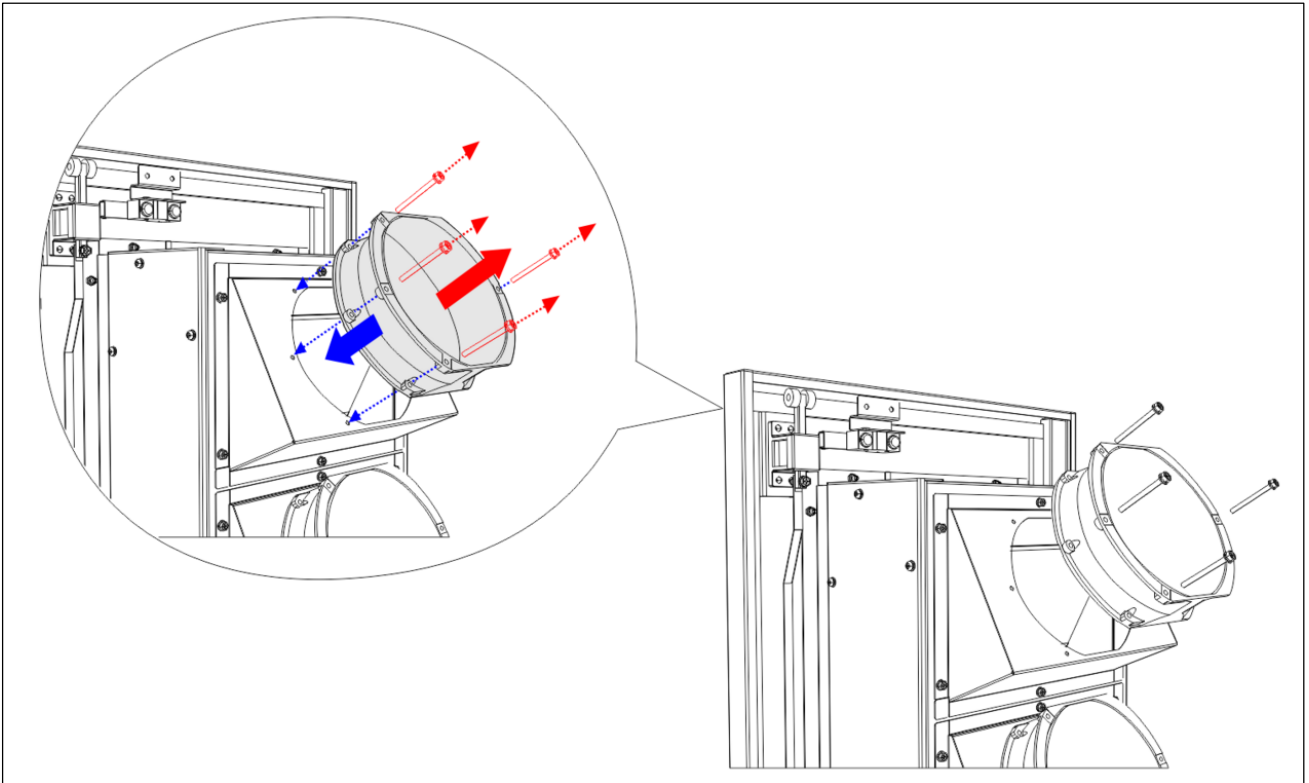

#### 4. AC contactor

Tools required: screwdriver

Replacement steps: ① Use a screwdriver to unscrew six screws fixing the bus bar in the AC contactor.

Note that these screws cannot be taken out and can only be unscrewed;

② Use a screwdriver to remove the fixing screw between the bus bar and the insulation column, and move the bus bar out of the AC contactor;

③ Use a screwdriver to remove the fixing screws in the upper right and lower left corners of the AC contactor. And then the AC contactor can be removed.

④ Replace with a new AC contactor in the opposite way to disassemble it.

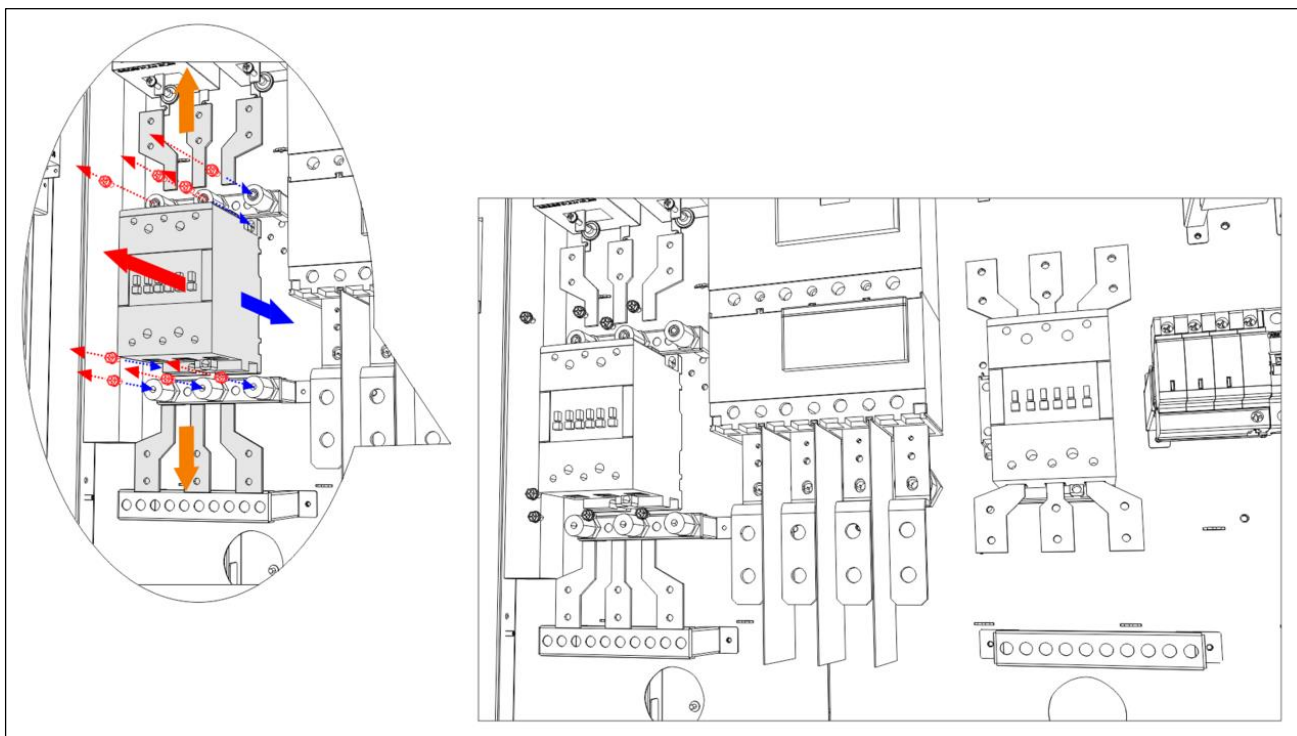

## 5. Transformer

Tools required: screwdriver

- Replacement steps:
- ① Use a screwdriver to remove the protective cover on the transformer and remove the connecting cable;
  - ② Use the screwdriver to remove the four screws of the fixed plate at the bottom of the transformer. And then the transformer can be removed;
  - ③ Remove the cable passing through the transformer from the bus bar, and pass the transformer through the cable.
  - ④ Replace with the new transformer in the opposite way to disassemble it.

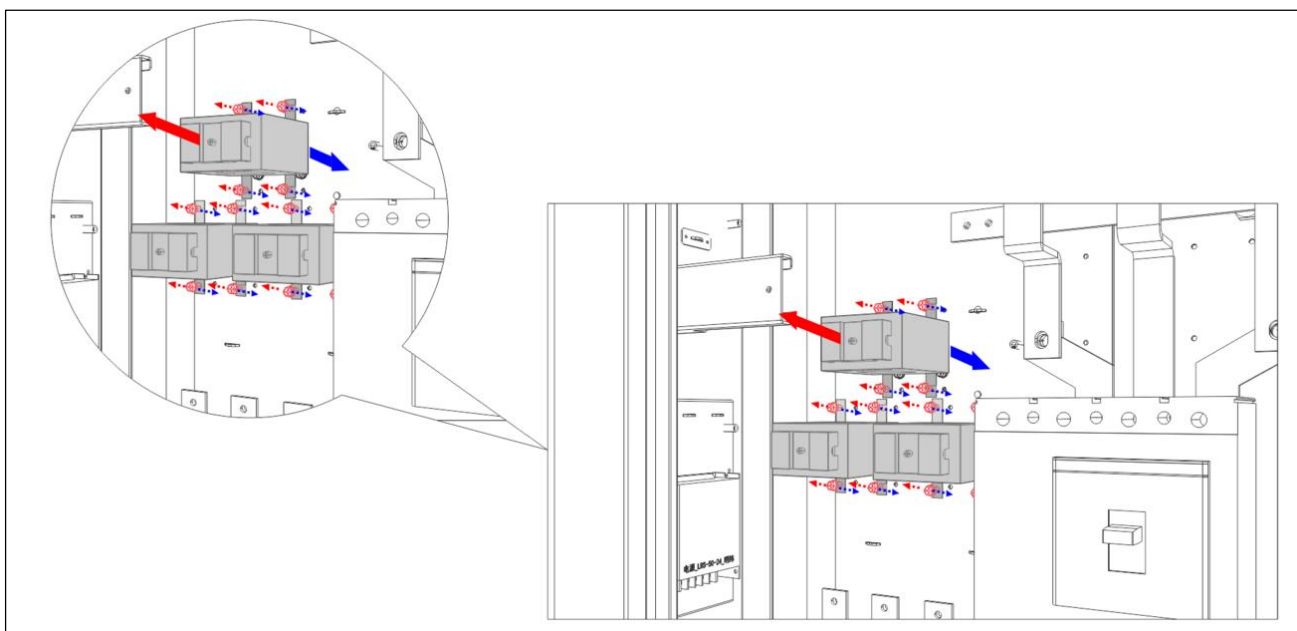

## 6 DC contactor

Tools required: screwdriver and socket wrench

- Replacement steps:
- ① Use a socket wrench to remove the bus bar on the DC contactor;
  - ② Remove the white signal line terminal on the side of the DC contactor;
  - ③ Use the screwdriver to remove the fixing screw in the upper right corner and lower left corner of the DC contactor. And then the DC contactor can be removed.
  - ④ Replace with a new DC contactor in the opposite way to disassemble it.

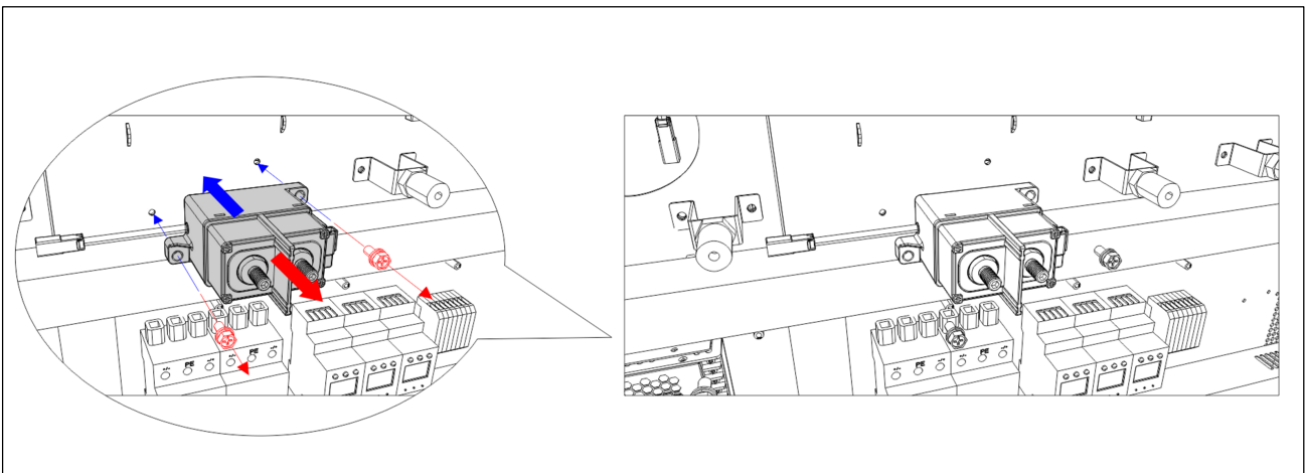
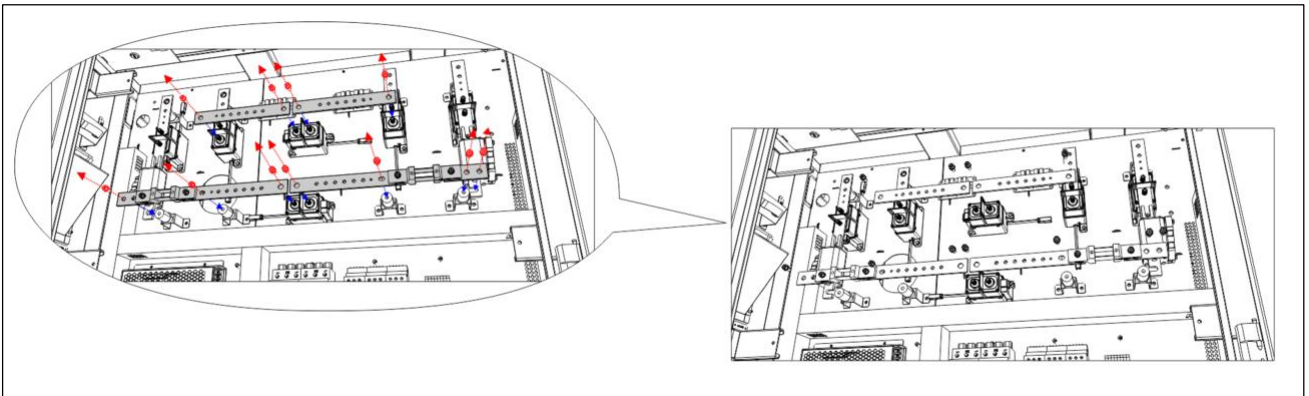

## 4 Guidance for replacement of dust screen

Tools required: screwdriver or electric tool and new dust screen

Replacement steps:

- ① Turn off the power supply and open the left and right doors of the cabinet;

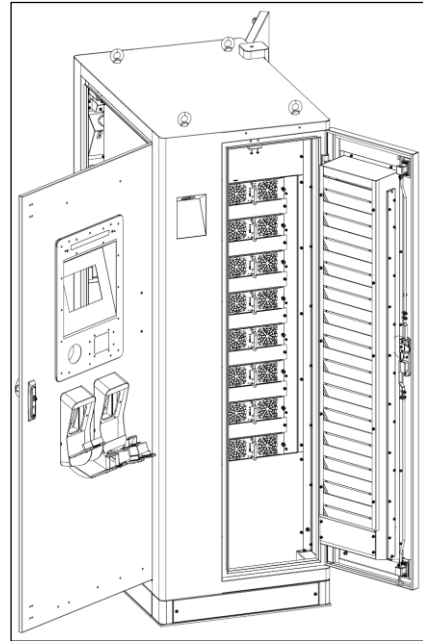
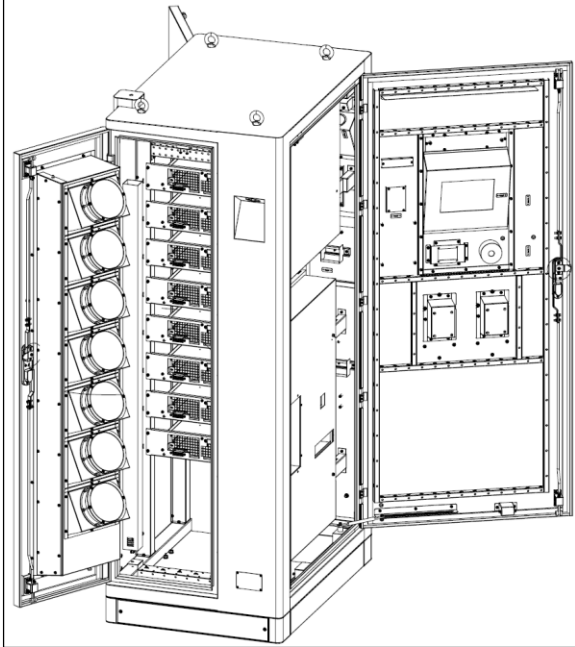

- ② Remove the left and right cover plates and their installation screws (M4×16) with an electric screwdriver.

Note: The left cover plate shall be lifted up for about 20mm, and then taken out. Do not lose the cover plate and installation screw. They will be used in future installation.

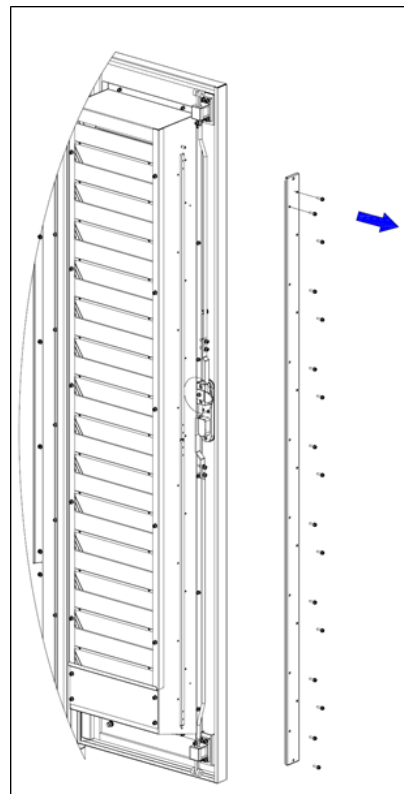
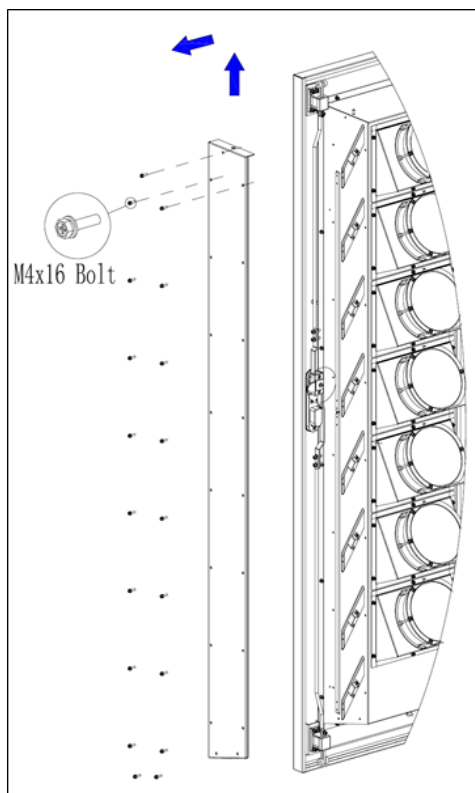



③ Use the drawing pipe of dust screen to draw out the old dust screen and scrap it;

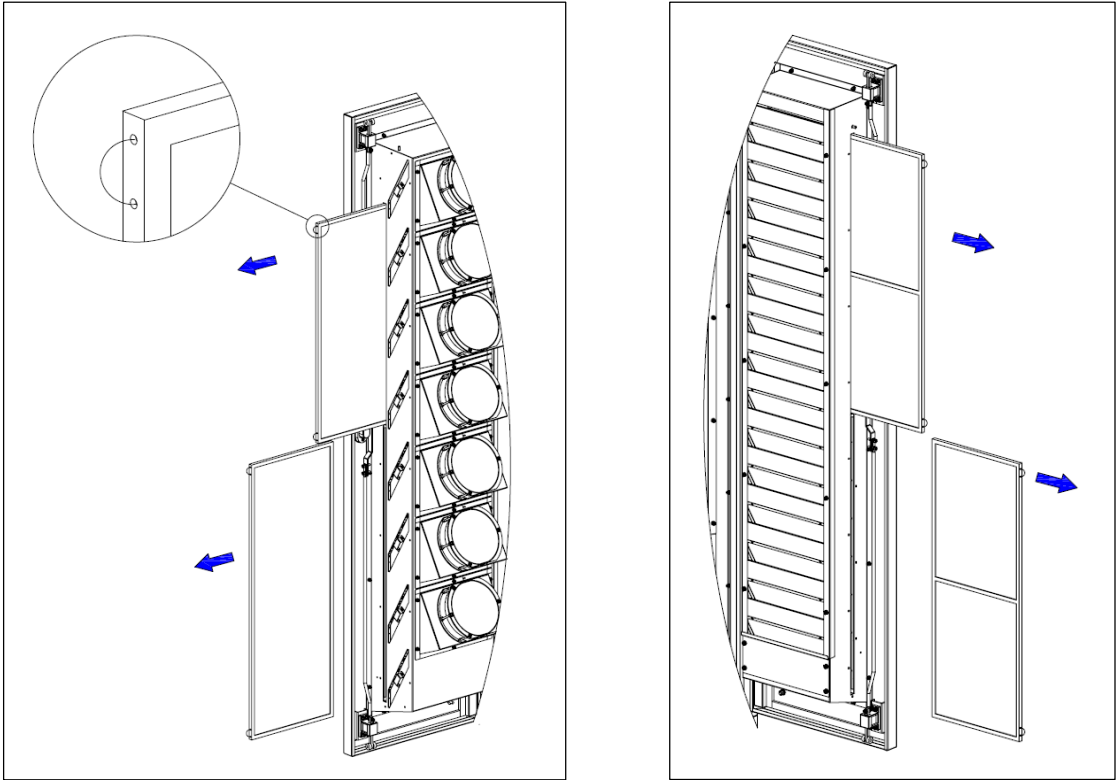

④ Insert the new dust screen with the same specification into the left and right side door respectively;

Note: One end of the pull ring is kept outside for the next change.

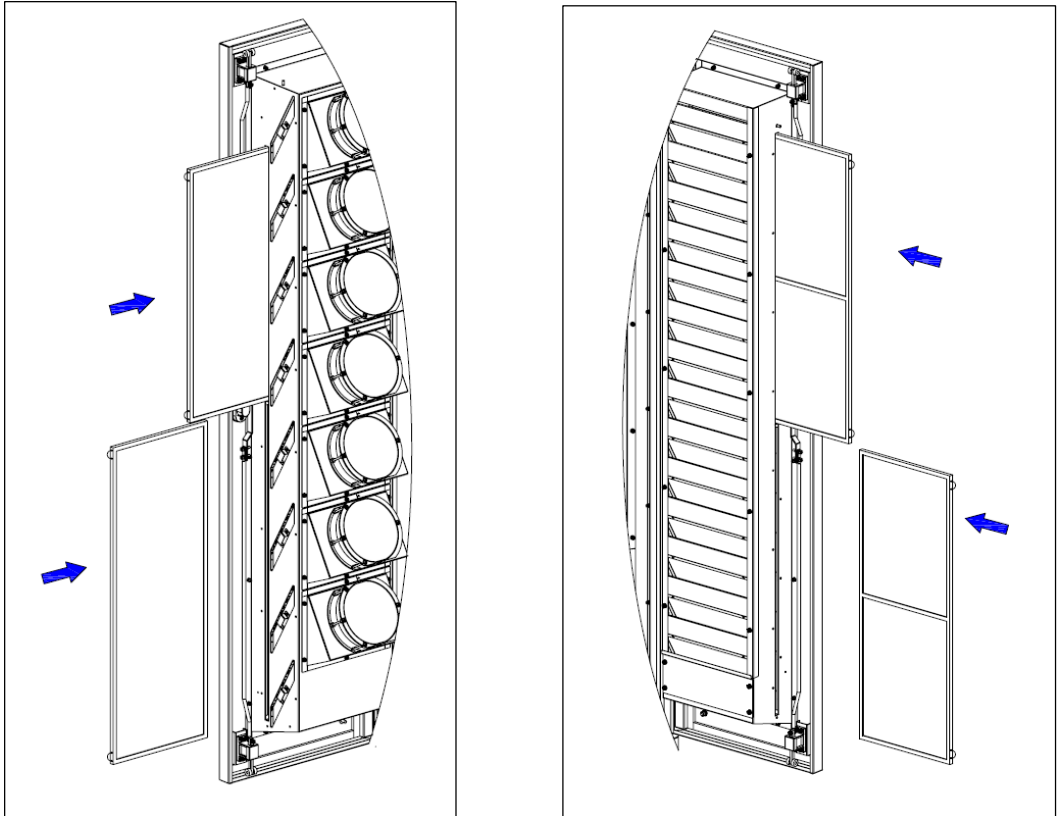

⑤ Install the side cover plate and lock the screw (M4×16). The reference torque of screw tightening:



16kgf. cm;

NOTE: The top of the cover plate shall be hung first for installation of the left cover plate, as shown in the figure. And then install the screw.

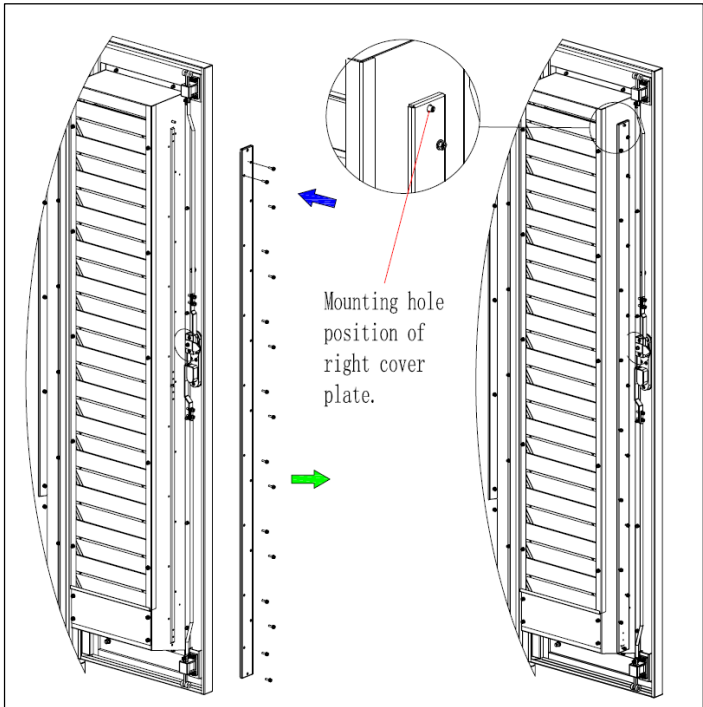
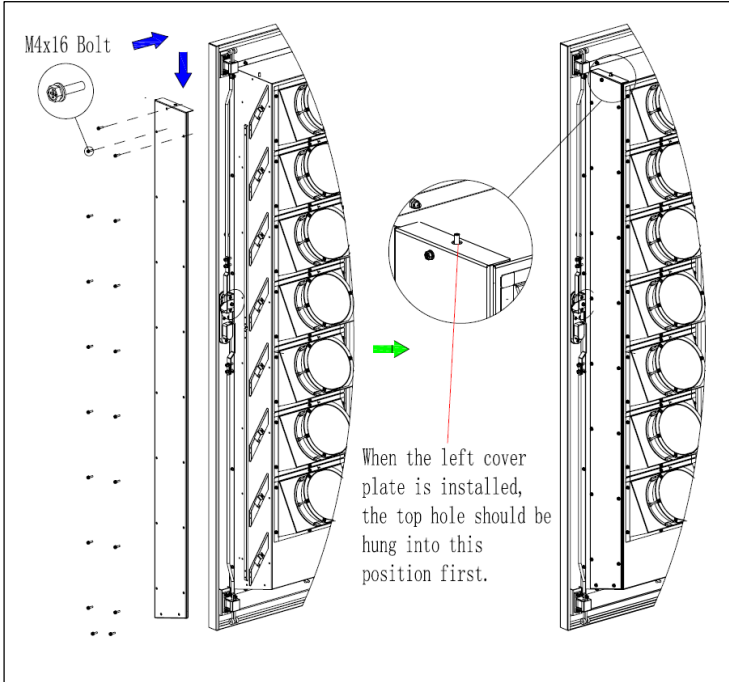

⑥ The dust screen has been replaced.

## 5 Common troubleshooting

No.	Content of failure	Cause of failure	Method of treatment
1	Abnormal communication of control panel	<ol style="list-style-type: none"> <li>1. The connection of CAN bus between TCU and controller of charging pile is loose;</li> <li>2. Error of CCU address setting;</li> <li>3. The anti-interference ability of CAN bus is not good or the bus matching resistance has a problem.</li> </ol>	<ol style="list-style-type: none"> <li>1. Use a multimeter to check whether the CAN communication line between TCU and the charging controller is connected abnormally, whether the matching resistance is connected reliably, and whether the shield layer of the communication line is effectively grounded;</li> <li>2. Check CCU address, dial No. 4 for No. 1 CCU, and dial No. 3 for No. 2 CCU;</li> <li>3. Replacement test. Change if TCU is damaged;</li> </ol>
2	Electric meter communication failure	<ol style="list-style-type: none"> <li>1. The connection between CCU and electric meter is loose</li> <li>2. The electric meter address, baud rate, check bit, stop bit and other settings have problems;</li> <li>3. Electric meter failure</li> </ol>	<ol style="list-style-type: none"> <li>1. Check whether the connection between CCU and electric meter is loose;</li> <li>2. Check whether the electric meter address, baud rate, check bit and stop bit are set properly ;</li> <li>3. Replacement test. If it has a failure, the electric meter shall be replaced.</li> </ol>
3	Action failure of emergency stop button	<ol style="list-style-type: none"> <li>1. The emergency stop button of the charging pile is pressed emergency stop button in the normal state, and the button has not been restored since it was pressed.</li> </ol>	<ol style="list-style-type: none"> <li>1. Turn the emergency stop button clockwise to return to normal;</li> <li>2. Replacement test. The damaged emergency stop button shall be replaced.</li> </ol>
4	Lightning protector failure	<ol style="list-style-type: none"> <li>1. The lightning protector is damaged;</li> </ol>	<ol style="list-style-type: none"> <li>1. Replacement test. The damaged lightning protector shall be replaced.</li> </ol>
5	DC lightning protector failure	<ol style="list-style-type: none"> <li>1. The lightning protector is damaged;</li> </ol>	<ol style="list-style-type: none"> <li>1. Replacement test. The damaged lightning protector shall be replaced.</li> </ol>
6	Access control failure	<ol style="list-style-type: none"> <li>1. The door is not closed;</li> <li>2. The line of the micro-motion travel switch is not inserted or damaged;</li> </ol>	<ol style="list-style-type: none"> <li>1. Close and lock the door again;</li> <li>2. Check whether the line of the micro-motion trip switch is inserted properly and the spring status is normal;</li> </ol>
7	Off-line	<ol style="list-style-type: none"> <li>1. Check whether the router has a network or the signal of the station is weak;</li> <li>2. Check whether the TCU network setting is correct (local IP, subnet mask, gateway, pile number, domain name address);</li> <li>3. The background is abnormal;</li> </ol>	<ol style="list-style-type: none"> <li>1. Check whether there is a network with a router directly connected to the laptop. Contact the local operator if not;</li> <li>2. Re-set the correct parameters if the TCU network settings are wrong;</li> <li>3. Contact the background for background state;</li> </ol>
8	Black screen	<ol style="list-style-type: none"> <li>1. Whether the power supply of TCU is lower than 12V;</li> <li>2. The power cord between the TCU and the display screen is loose;</li> </ol>	<ol style="list-style-type: none"> <li>1. The auxiliary power supply is damaged or the connection is wrong. Check the wiring. If the wiring is correct, replace the auxiliary power supply;</li> <li>2. Tighten the power cord between the TCU and the display screen again;</li> </ol>

		3. The display screen is damaged;	3. If it is damaged, replace the display screen;
9	Over-temperature failure of charging pile	1. There is dust accumulation on the dust screen at the outlet; 2. The internal temperature of the charging pile is too high;	1. Remove the dust accumulation on the dust screen; 2. Detect whether the fan at the air outlet has a failure and whether there is dust accumulation at the air inlet.
10	DC contactor failure	1. The DC contactor is adhered; 2. The DC contactor refuses to move or makes a false action;	1. Replace the DC contactor
11	Output fuse failure	1. The fuse is damaged;	1. Replace the fuse;
12	Incoming circuit breaker status failure/ Electric leakage failure of incoming circuit breaker	1. The electric leakage protection of the circuit breaker trips;	1. Check whether the electric leakage current of the charging pile exceeds the the electric leakage protection threshold of the circuit breaker. If so, contact the manufacturer.
13	Input overvoltage failure	1. The grid voltage fluctuates and the input voltage exceeds the protection threshold of input voltage of the charging pile; 2. Sampling error of charging pile.	1. Use a multimeter to measure whether the input three-phase voltage exceeds the protection threshold of input voltage of the charging pile. If so, contact the local power grid or temporarily raise the input voltage protection threshold of the charging pile; 2. Contact the manufacturer for handling.
14	Input undervoltage failure	1. The grid voltage fluctuates and the input voltage is lower than the input voltage protection threshold of the charging pile. 2. Sampling error of the charging pile.	1. Use a multimeter to measure whether the input three-phase voltage is lower than the protection threshold of input voltage of the charging pile. If so, contact the local power grid or temporarily reduce the input voltage protection threshold of the charging pile. 2. Contact the manufacturer for handling.

## 6 Emergency unlock

See next page for details.

## Emergency Manual for Quick Charger Connector (One-push type) for EV (How to detach the connector when it cannot be removed)

---

### 1. Introduction

This manual shows how to detach the connector when it cannot be removed under some abnormal situation.

It may be caused by malfunction of electric lock ,and in order to detach the connector you need to release the electric lock using the tool below.

### 2. Caution

Make sure to "TURN OFF POWER" before using the tool.

Please take care not to damage your car.

### 3. Tool

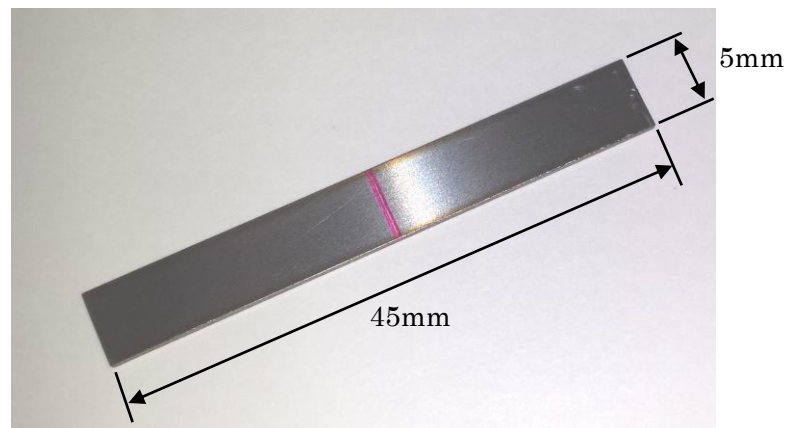

The picture of urgent detaching tool

## 4. Procedure

- (1) Insert the urgent detaching tool in the hole for urgent detaching at the side of connector grip. Make the RED LINE on the tool align with the surface of the grip. (See the picture)

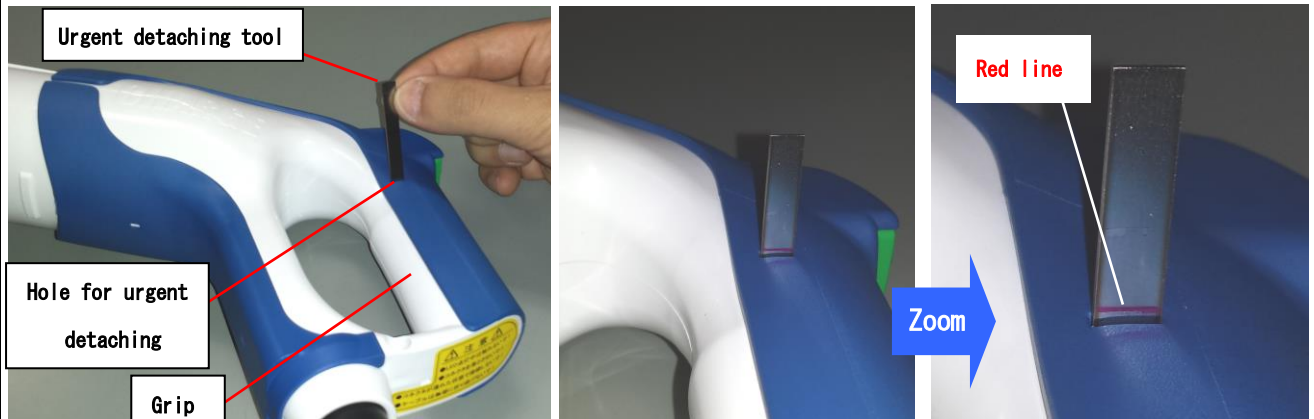

- (2) Then, push to lean the tool to upper side of connector.

(See the yellow arrow in the picture)

- (3) Then, remove the tool, push release button and pull out the connector.



### Detailed mechanism for your reference

The connector is locked and cannot be removed when the lock pin sticks out from the electric lock.

In an abnormal situation the lock pin does not retract for some reason.

So you can detach the connector by forcibly retracting the lock pin using the tool.

